

RECOMMENDED PCB LAYOUT
GENERAL TOLERANCE ± 0.05

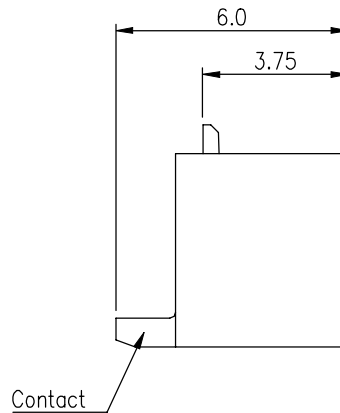
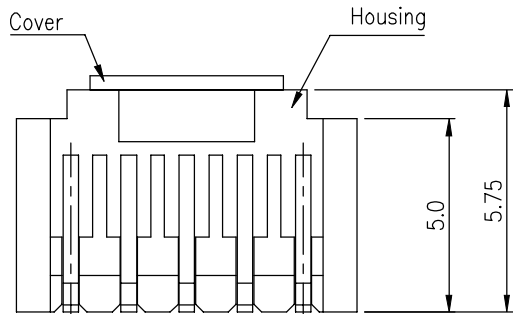

NOTES:

1. MATERIAL:
 - 1.1 HOUSING: HALOGEN FREE PLASTIC, HIGH TEMP., UL94V-0.
 - 1.2 CONTACT: COPPER ALLOY
2. FINISH:
 - 2.1 CONTACT: 50~100u" NICKEL UNDERPLATING OVERALL.
 - 1:GOLD FLASH PLATING(1~3u") .
 - L:100~200u" TIN PLATING ON SOLDER TAILS,
 - N:100~200u" PURE TIN(MATT TIN)PLATING OVERALL.
3. REFLOW SOLDER CAPABLE TO 260°C PER ACES SPEC.
4. SPEC. PLS. REFER TO PS-50289-XXXX-XXX
5. PACKAGE PLS. REFER TO 88738-XXXX-XX-TRP
6. PART NUMBER

P/N LEGEND

52249-XXX X X-XXX

CTKS

PACKING

- 0:TAPE & REEL
- 7:TAPE & REEL WITH COVER
- 8:TUBE WITH COVER

XXX	Material&Color	Cover	PACKAGE
001	LCP&White	W/H Cover	88738-XXXX-XX

PLATING
L:LEAD FREE (PURE TIN)
N:MATT TIN
1:GOLD FLASH PLATING

CKT	Dim A	Dim B	Dim C	Dim D
5	6.0	8.8	8.2	7.8

QUALITY SYMBOLS MAJOR CRITICAL GENERAL TOLERANCES (UNLESS SPECIFIED) X. ± 0.5 X ± 0.25 .XX ± 0.15 .XXX ± 0.1 ANGLES $\pm 2^\circ$	DRAWN BY Huang,ShunSen DATE 21/03/03	
	CHECKED BY Lu,Jing Quan DATE 21/03/03	
	APPROVED BY Hsieh,Fu Yu DATE 21/03/03	SIZE A4 RFQ NO. RFQ-2102008
UNITS mm SCALE - : -	 SHEET NO. 1 OF 1	REV 1 DWG NO. 52249-XXXX-XXX